

GRC-280SH/PH

金属后盖
Metal Endbell

输出功率: 约0.5~25W
OUTPUT: APPROX 0.5~25W

代表的用途/玩具 模型

- 电动玩具
- 电动塑胶模型
- 家用电器
- 电动理发机
- 按摩器 振动器

Typical Applications/Toys and Models

- Motorized Toy
- Motorized Plastic Model
- Household Appliances
- Hair Clipper
- Massager/Vibrator

型号 Model	电压 Voltage		无负载 No Load		最高效率时性能(%) At Maximum Efficiency				堵转 Stall	
	使用电压 Operating Range	常用 Nominal	转速(r/min) Speed	电流(A) Current	转速(r/min) Speed	电流(A) Current	扭矩(gcm) Torque	输出(W) Output	扭矩(gcm) Torque	电流(A) Current
GRC-280PH-22125	3~6	4.8V	5500	0.09	4616	0.47	30.9	1.47	193	2.85
GRC-280PH-14240	18~24	24V	15000	0.07	12895	0.43	50.7	6.70	361	2.63
GRC-280SH-3248	6~9	7.2V	23000	0.45	19837	2.82	63.3	12.87	460	17.7
GRC-280SH-14260	24~30	30V	18000	0.07	16035	0.57	55	9	504	4.7

GRC-280PH-22125

4.8V

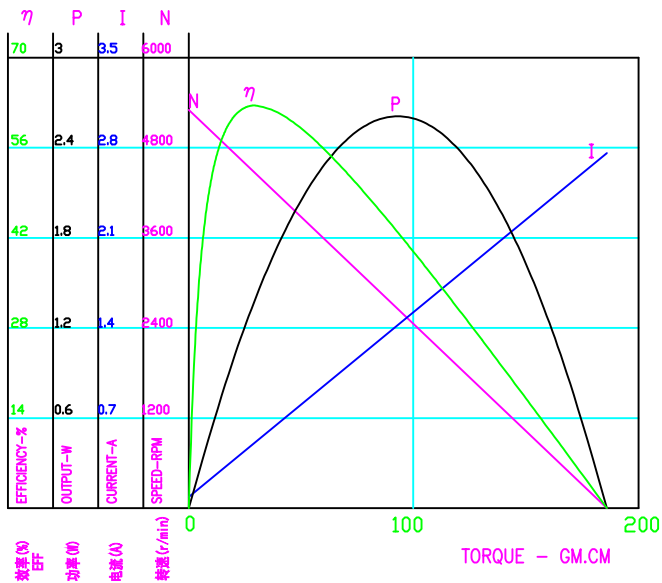

GRC-280SH-14260

30V

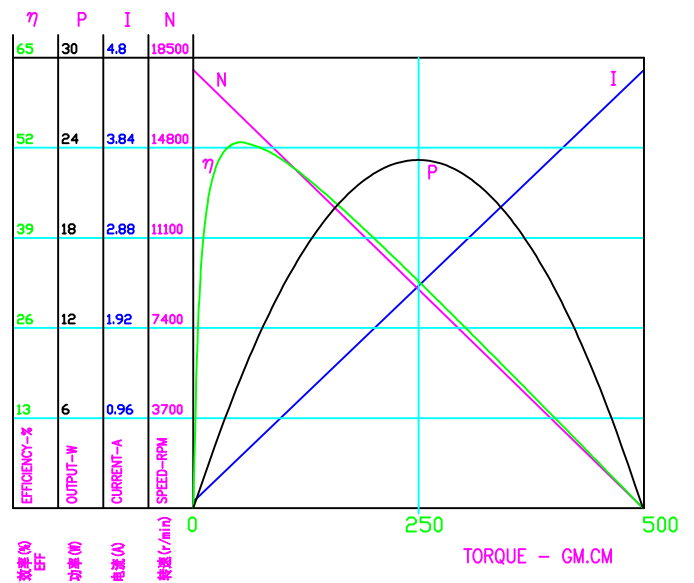

单位: mm

DIRECTION OF ROTATION

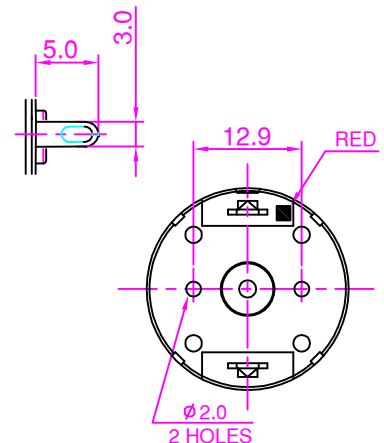
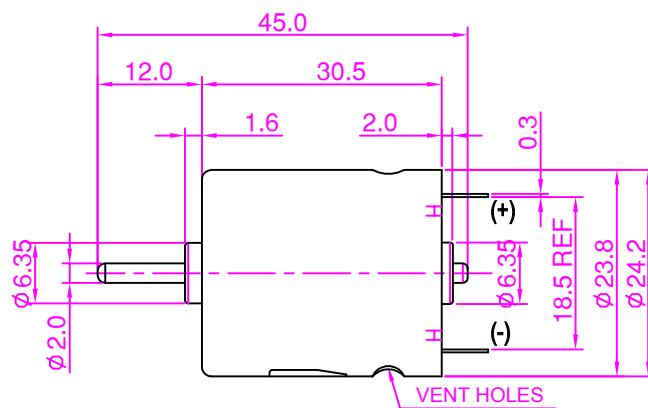
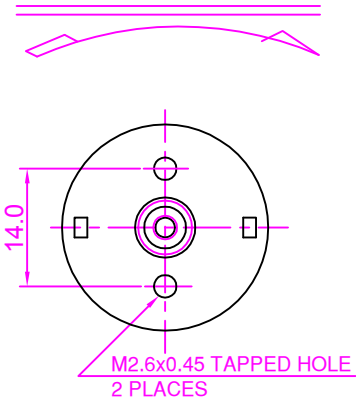

重量: 约42g
WEIGHT: 42g(APPROX)