

# GRS-550VF

输出功率: 约50~200W  
OUTPUT: APPROX 50~200W

代表的用途/电动工具

- 钻孔机
- 空气压缩机
- 园林电动工具

Typical Applications/Cordless Power Tools

- Drill & Screwdriver
- Air Compressor
- Cordless Garden Tool

注: 1) 通过电动工具“FFU”测试标准GOOD级

2) 马达轴出端均可选配滚珠轴承

3) 可根据要求通过EMC

型号 Model	电压 Voltage		无负载 No Load		最高效率时性能(%) At Maximum Efficiency				堵转 Stall	
	使用电压 Operating Range	常用 Nominal	转速(r/min) Speed	电流(A) Current	转速(r/min) Speed	电流(A) Current	扭矩(gcm) Torque	输出(W) Output	扭矩(gcm) Torque	电流(A) Current
GRS-550VF-7524	6~15 V	12.0V	20000	1.60	17755	12.65	518	94.35	4615	100
GRS-550VF-7030	12~16 V	14.4 V	19500	1.20	17403	9.96	654	116.7	5100	76
GRS-550VF-6038	12~20 V	18.0 V	19000	0.95	17114	10.0	550	96.5	5541	90

GRS-550VF-7524

12.0V

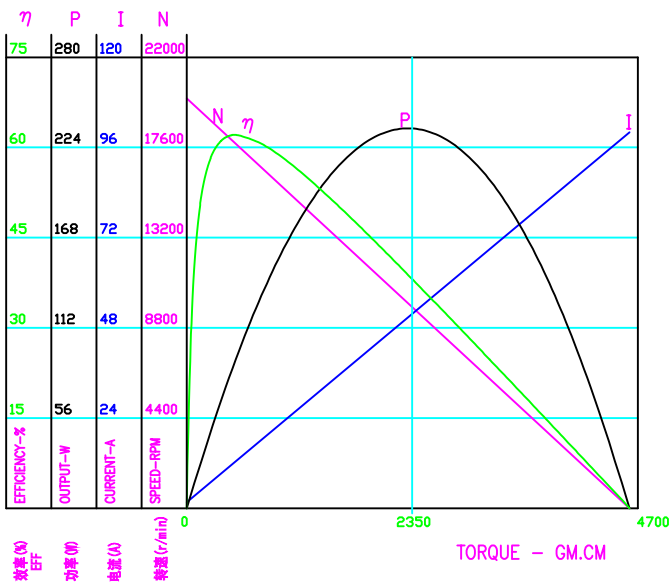

GRS-550VF-7030

14.4V

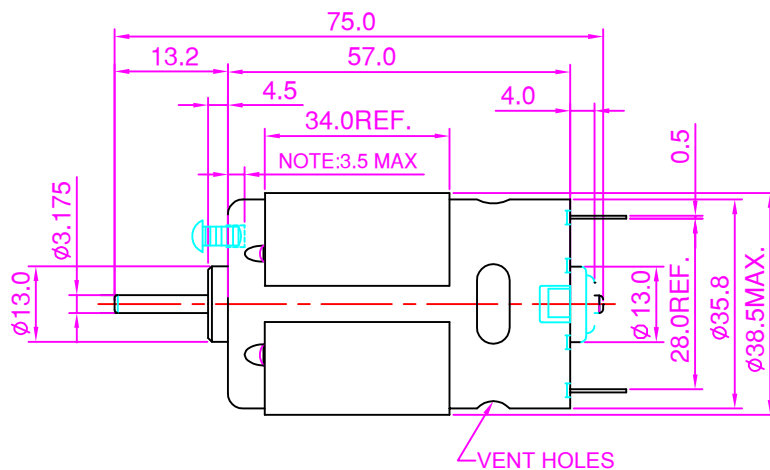
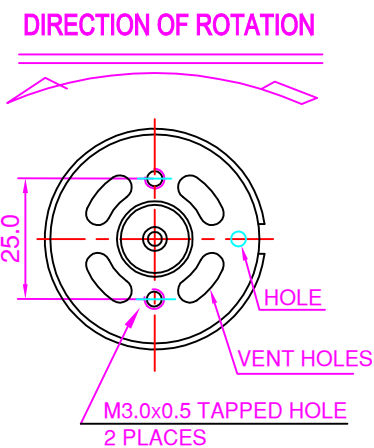
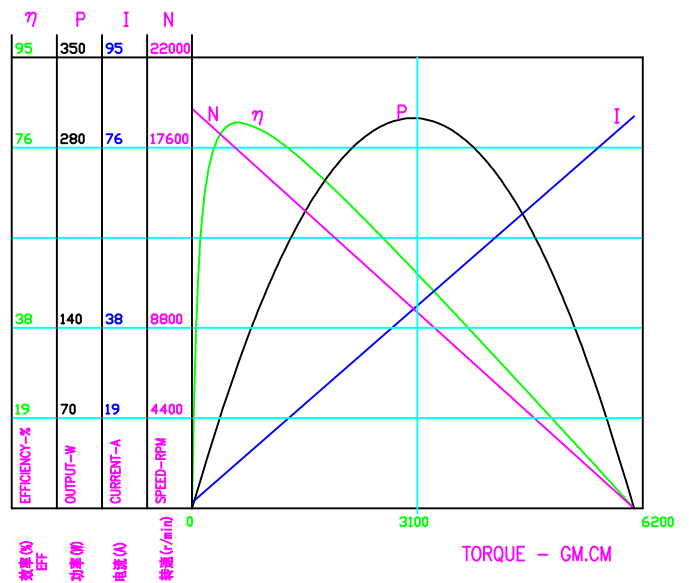

重量: 约255g  
WEIGHT: 255g(APPROX)

