

# GRS-540 · 545

输出功率: 约2.0~60W  
OUTPUT: APPROX 2.0~60W

## 代表的用途/家用电器

- 吸尘器
- 电动工具
- 空气压缩机 • 钻孔机
- 玩具和模型
- 无线电操纵模型

## Typical Applications/Household Appliances

- Vacuum Cleaner
- Cordless Power Tools
- Air Compressor • Drill
- Toys And Models
- Radio Control Model

型号 Model	电压 Voltage		无负载 No Load		最高效率时性能(%) At Maximum Efficiency				堵转 Stall	
	使用电压 Operating Range	常用 Nominal	转速(r/min) Speed	电流(A) Current	转速(r/min) Speed	电流(A) Current	扭矩(gcm) Torque	输出(W) Output	扭矩(gcm) Torque	电流(A) Current
GRS-540SF-7024	9.6~12 V	10.8 V	28500	1.80	24651	11.53	218	55.1	1615	73.8
GRS-540SF-7527	10.8~12 V	12 V	26000	1.5	21824	7.8	228	51	1420	41
GRS-545SH-18150	12~32 V	24 V	5600	0.12	4560	0.53	167	7.82	900	2.30
GRS-545VF-4526	14.4~24 V	18 V	21800	0.78	19127	5.6	376	73.7	3067	40

## GRS-540SF-7024

10.8V

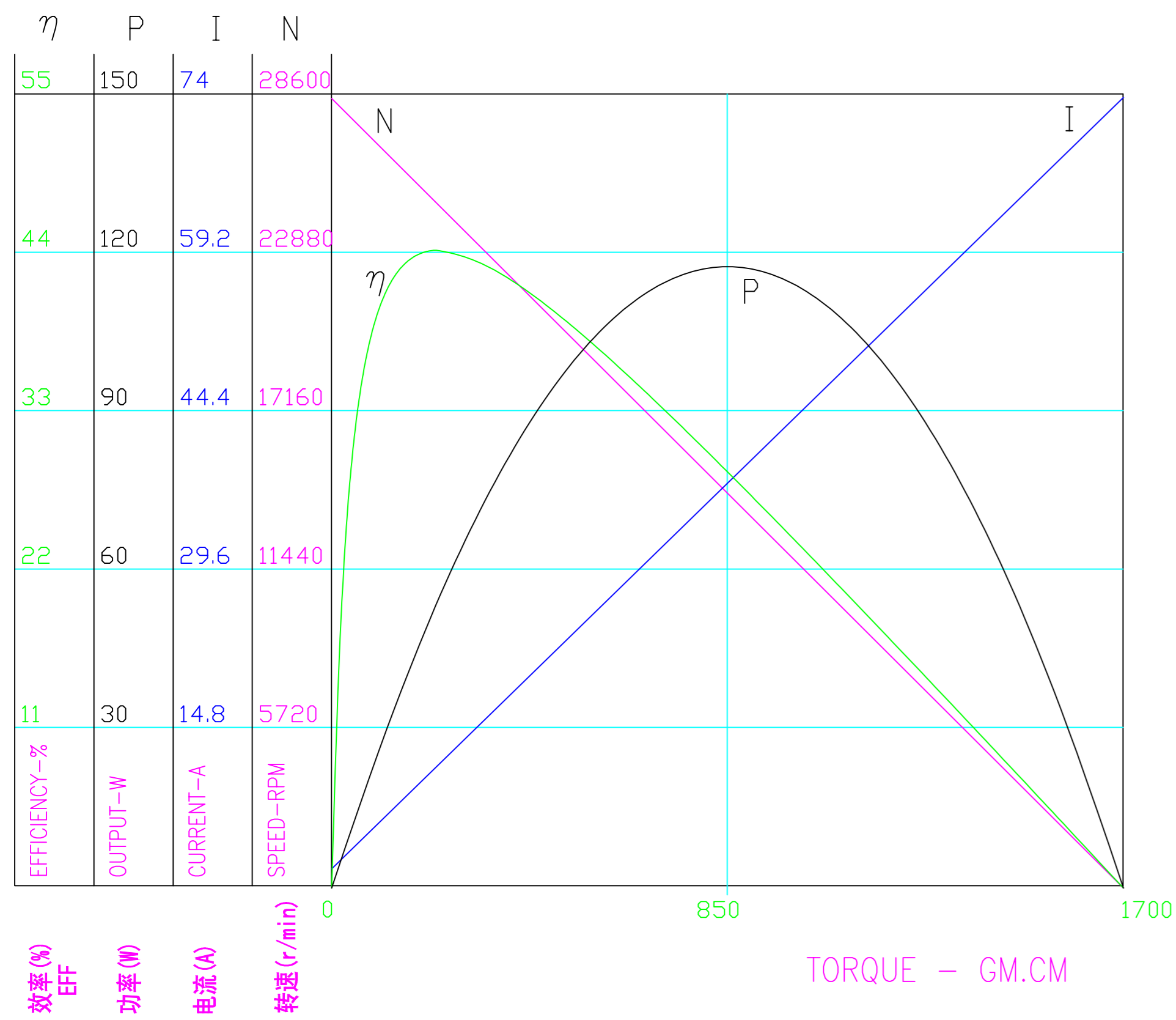

## GRS-545VF-4526

18.0V

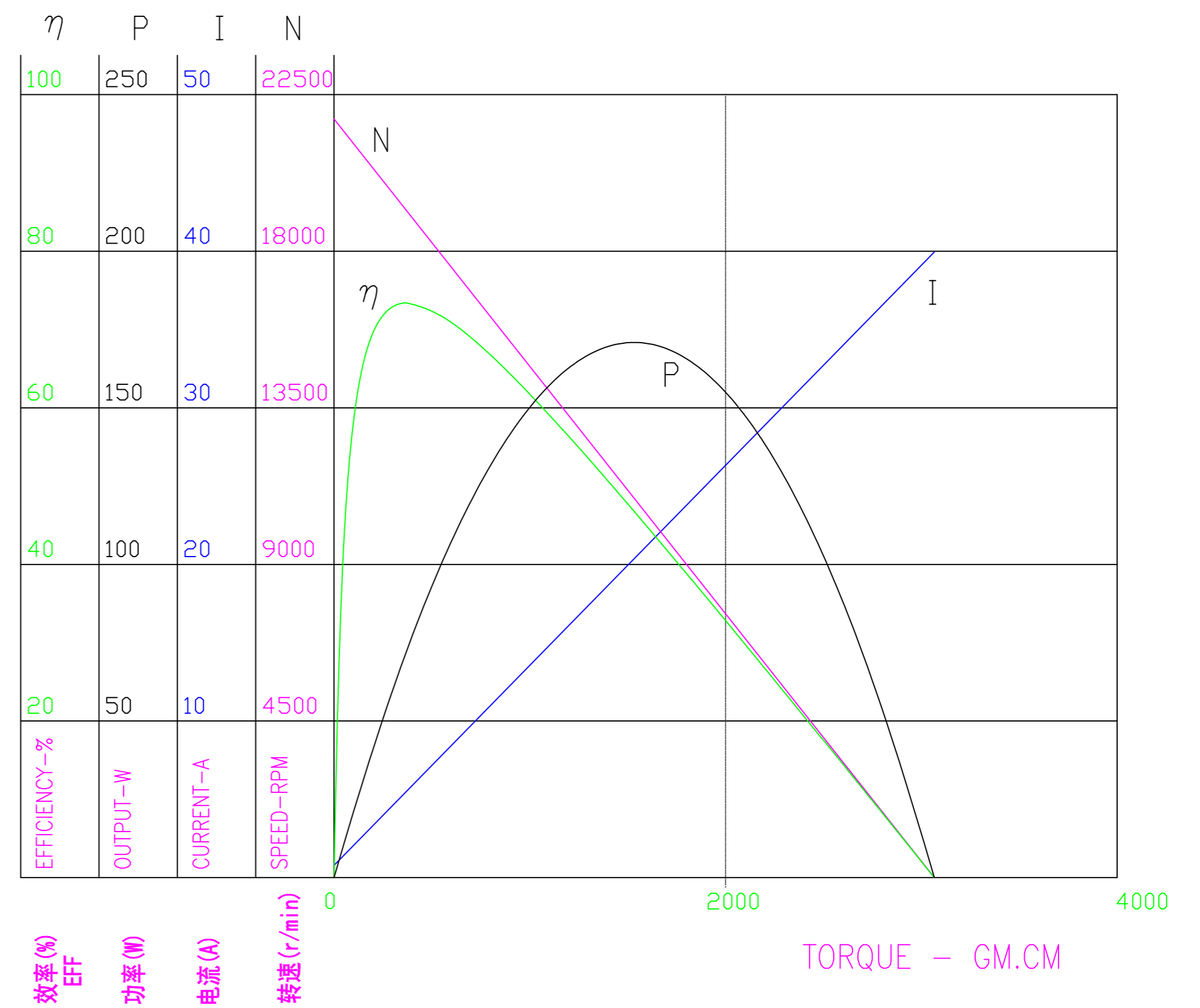

单位: mm

## DIRECTION OF ROTATION

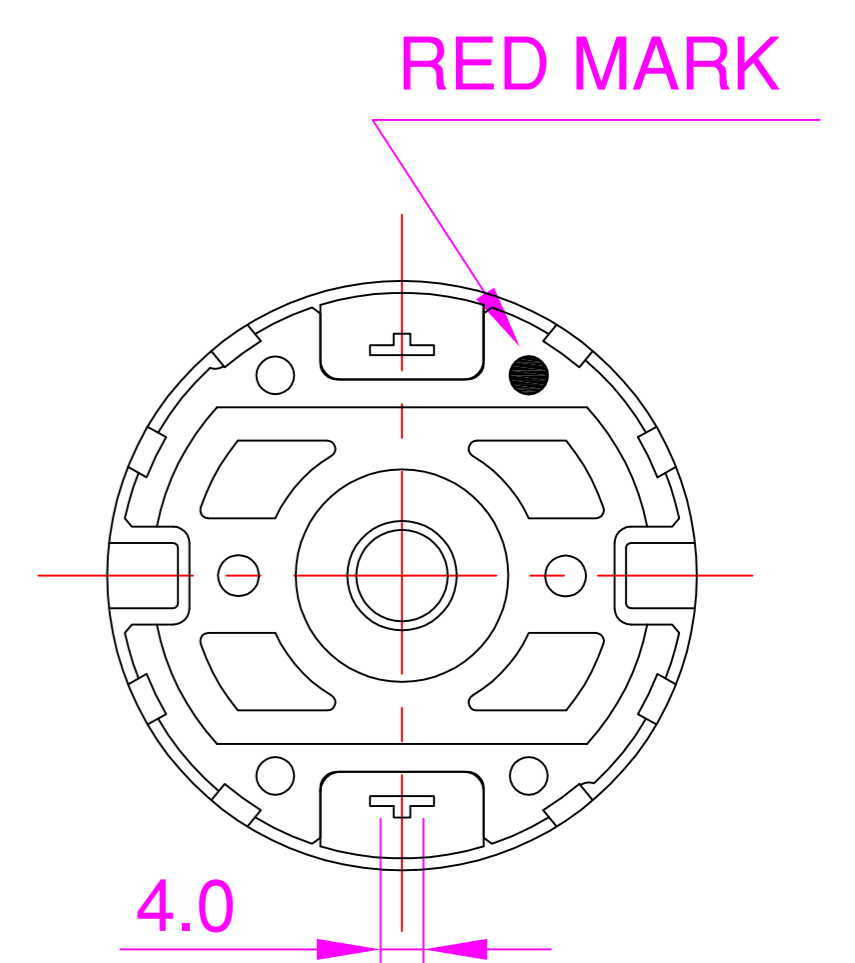
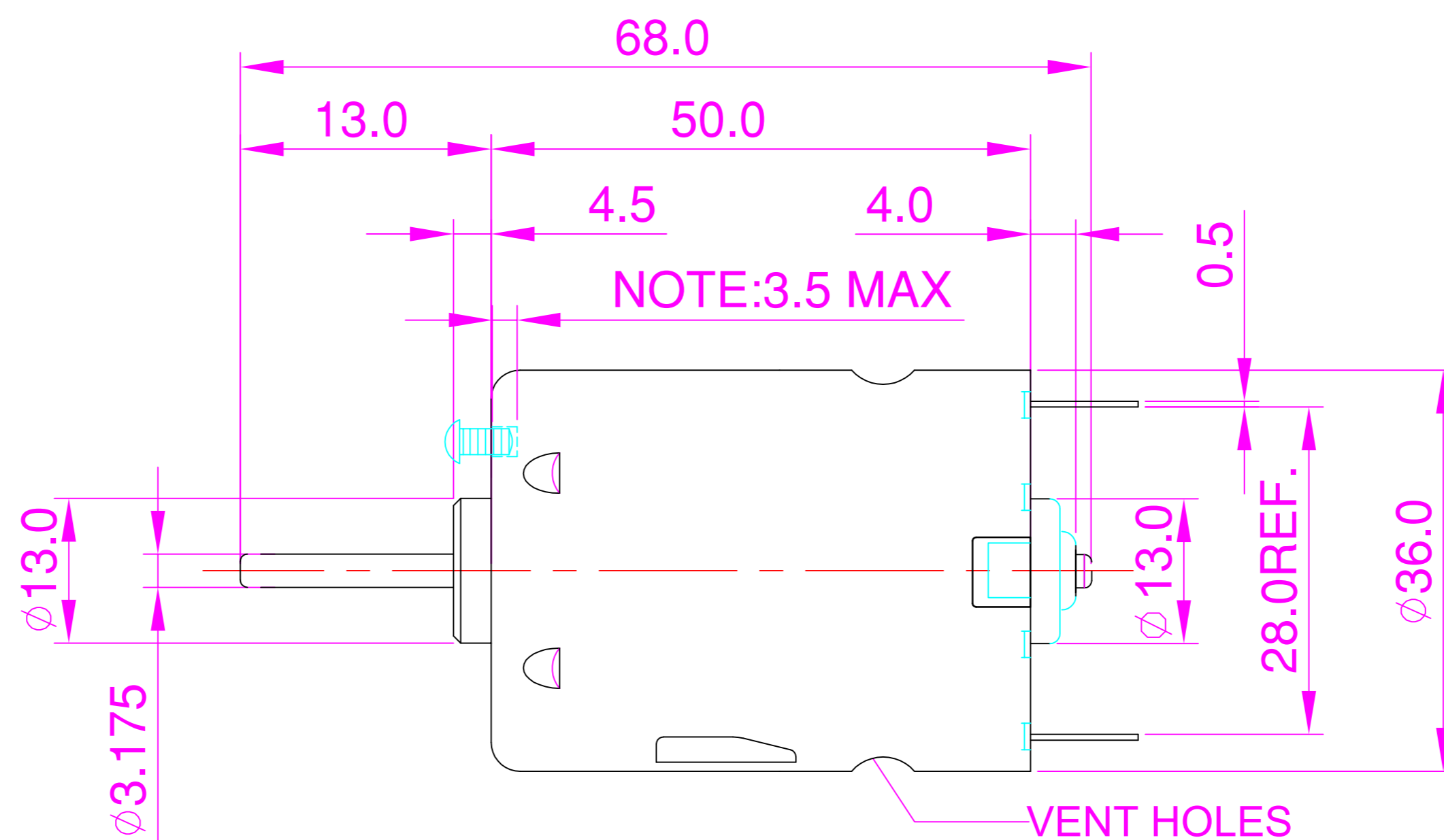
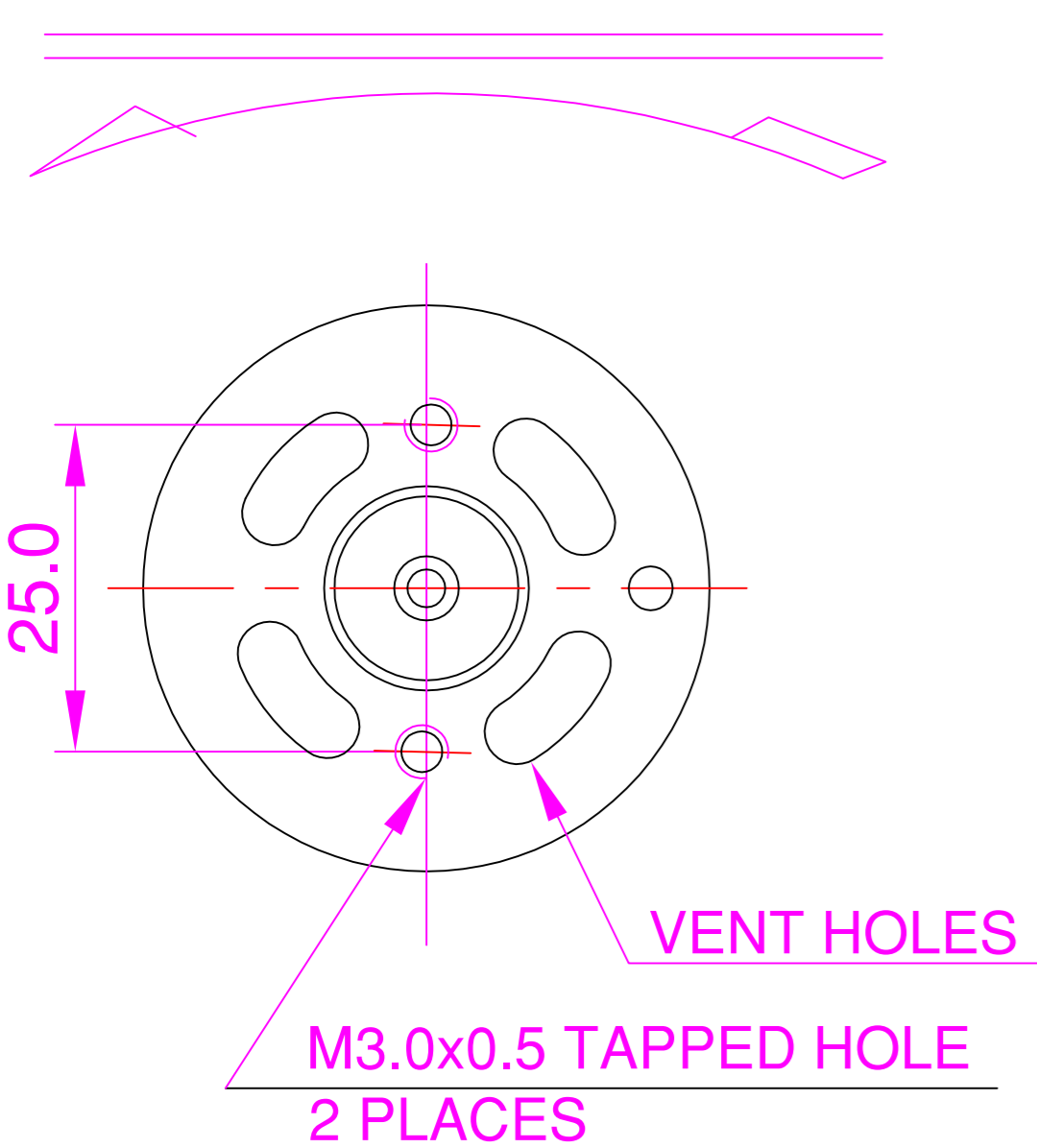

重量: 约160g  
WEIGHT: 160g(APPROX)