

GRZ-775VF / WF

输出功率: 约20~300W
OUTPUT: APPROX 20~300W

代表的用途

- 电动工具
- 办公自动化设备

Typical Applications

- Power Tool
- Office Automation Equipments

注: 1) 通过电动工具“FFU”测试标准GOOD级
2) 马达轴出端均可选配滚珠轴承

型号 Model	电压 Voltage		无负载 No Load		最高效率时性能(%) At Maximum Efficiency				堵转 Stall	
	使用电压 Operating Range	常用 Nominal	转速(r/min) Speed	电流(A) Current	转速(r/min) Speed	电流(A) Current	扭矩(gcm) Torque	输出(W) Output	扭矩(gcm) Torque	电流(A) Current
GRZ-775VF-8012	6~18 V	14.4V	19000	2.9	16302	17.5	1126	188	7931	106
GRZ-775VF-8015	6~20 V	18.0 V	18000	2.2	15761	15.5	1273	206	10236	109
GRZ-775WF-9013	6~20 V	18.0 V	21000	2.8	18554	21.3	1538	293	13209	161

GRZ-775VF-8015 18.0V

GRZ-775WF-9013 18.0V

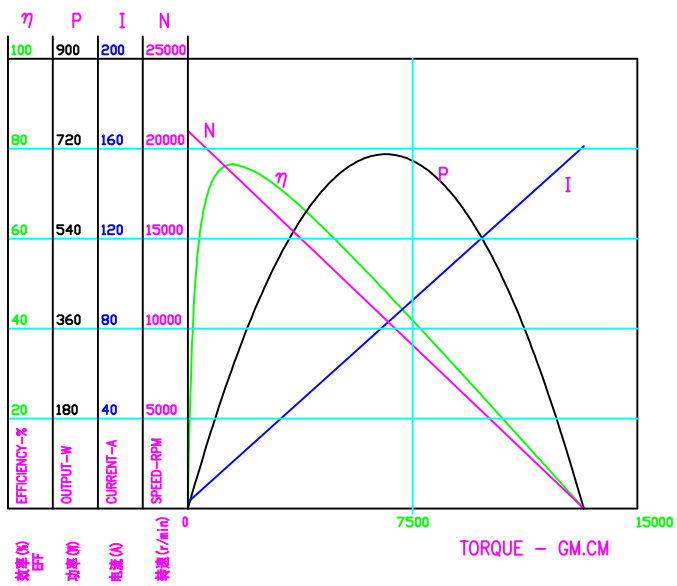
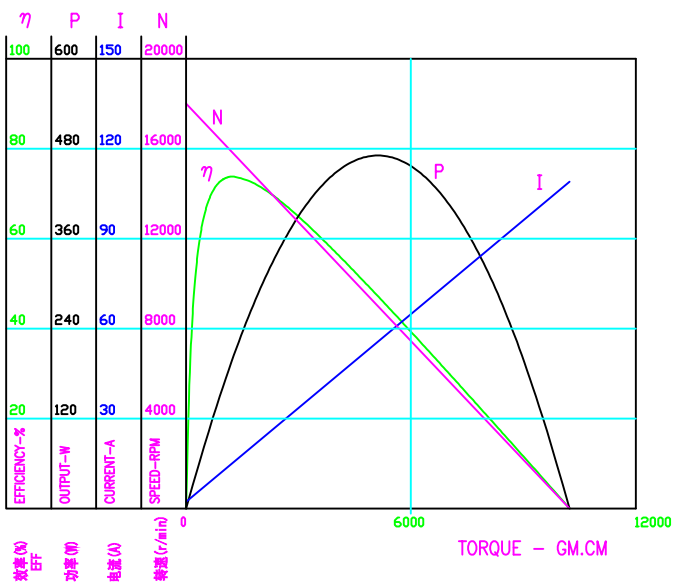

DIRECTION OF ROTATION

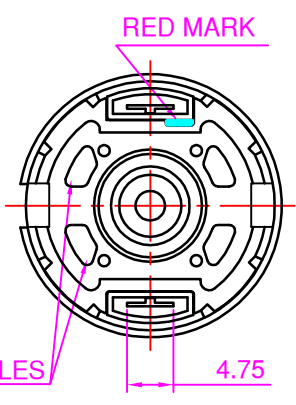
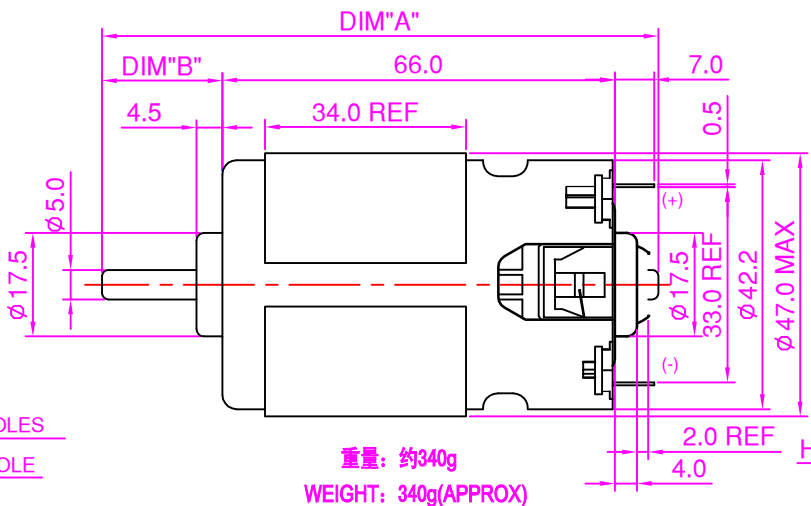
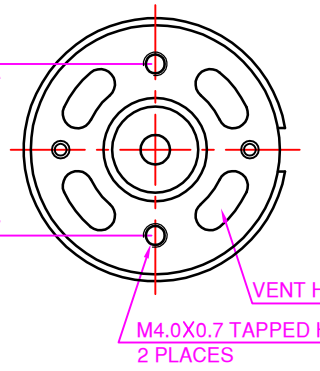
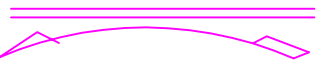

CCW+ 单位: mm