

GRZ-735WF

输出功率: 约10~300W
OUTPUT: APPROX 10~300W

代表的用途

- 园艺工具
- 电动工具

Typical Applications

- Power & Garden Tools
- Power Tool

注: 1) 通过电动工具“FFU”测试标准GOOD级
2) 马达轴出端均可选配滚珠轴承

型号 Model	电压 Voltage		无负载 No Load		最高效率时性能(%) At Maximum Efficiency				堵转 Stall	
	使用电压 Operating Range	常用 Nominal	转速(r/min) Speed	电流(A) Current	转速(r/min) Speed	电流(A) Current	扭矩(gcm) Torque	输出(W) Output	扭矩(gcm) Torque	电流(A) Current
GRZ-735WF-8021	12~20 V	18 V	16000	1.8	14176	14	1265	184	11098	108
GRZ-735WF-9016	12~20 V	18 V	21000	2.5	18637	19.72	1377.3	263.3	12240	156

GRZ-735WF-8021

18.0 V

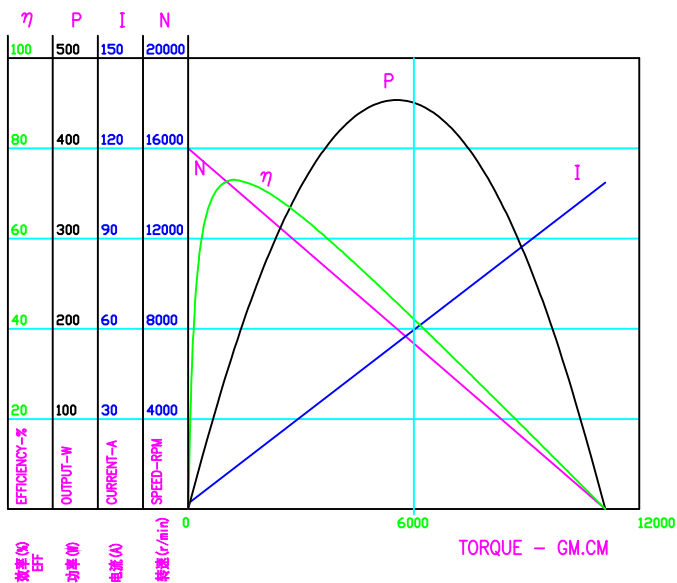

GRZ-735WF-9016

18.0 V

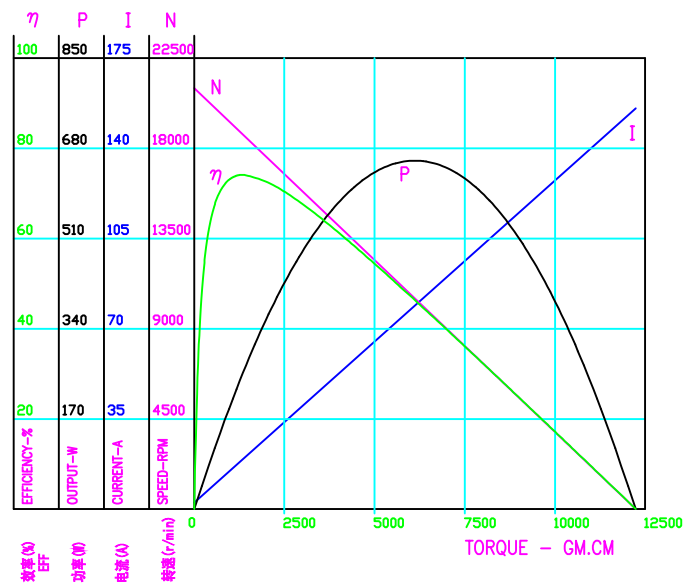

DIRECTION OF ROTATION

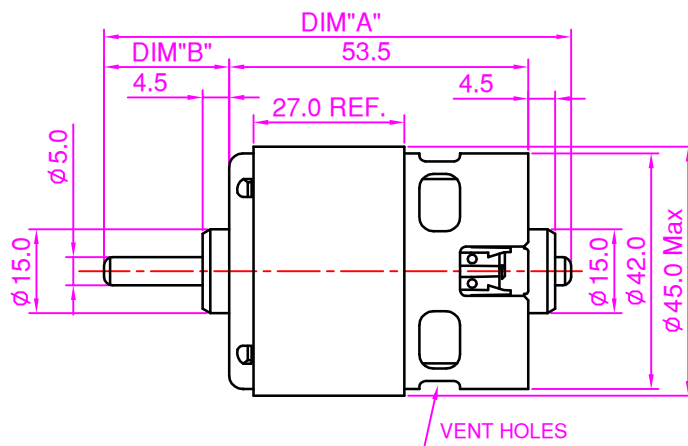
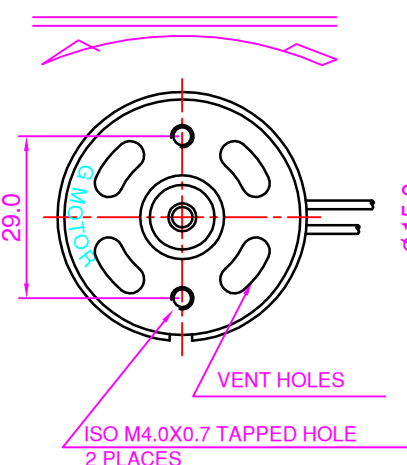

CCW+

单位: mm

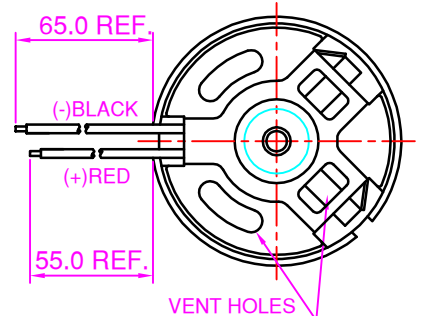

重量: 约290g
WEIGHT: 290g(APPROX)