

GRS-750VF

输出功率: 约15.0~250W
OUTPUT: APPROX 15.0~250W

代表的用途

- 电动工具
- 办公自动化设备

Typical Applications

- Power Tool
- Office Automation Equipments

注: 1) 通过电动工具“FFU”测试标准GOOD级

2) 马达轴出端均可选配滚珠轴承

型号 Model	电压 Voltage		无负载 No Load		最高效率时性能(%) At Maximum Efficiency				堵转 Stall	
	使用电压 Operating Range	常用 Nominal	转速(r/min) Speed	电流(A) Current	转速(r/min) Speed	电流(A) Current	扭矩(gcm) Torque	输出(W) Output	扭矩(gcm) Torque	电流(A) Current
GRS-750VF-7530	6~18 V	14.4V	20500	2.4	17608	14.6	787	142	5576	89
GRS-750VF-7039	6~20 V	18.0V	19500	1.8	16969	12	860	150	6630	81

GRS-750VF-7530

14.4V

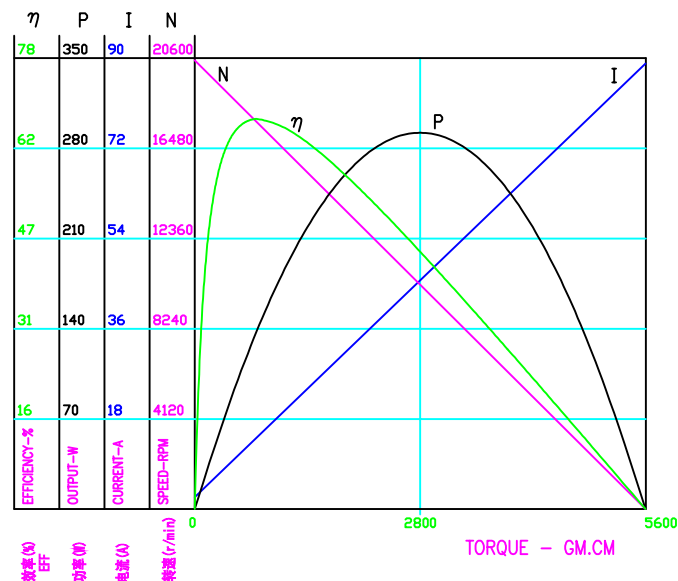

GRS-750VF-7034

18.0V

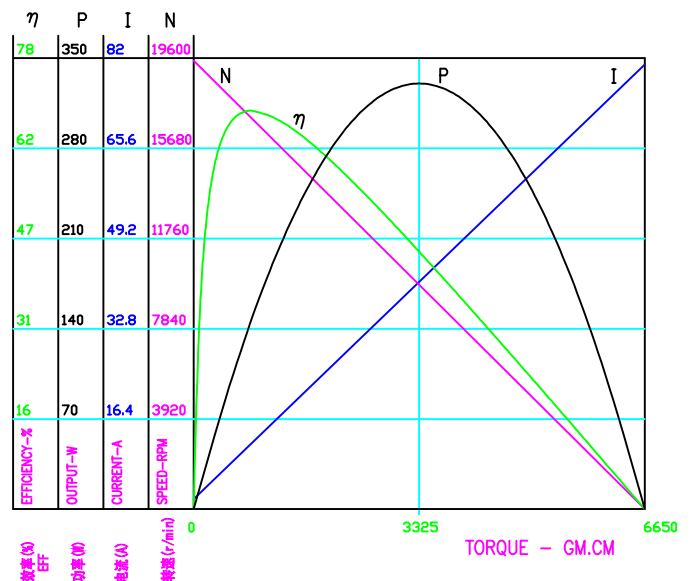

DIRECTION OF ROTATION

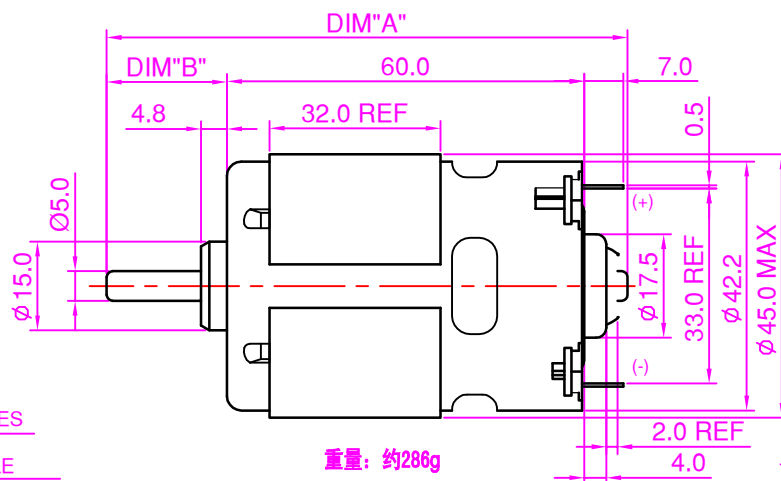
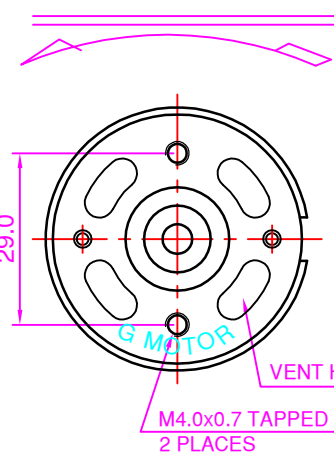

CCW+ 单位: mm

