

# GRS-5512

输出功率: 约9.0~90W  
OUTPUT: APPROX 9.0~90W

## 代表的用途/电动工具

- 手提式工具
- 各种泵机
- 理发剪
- 碎纸机
- 钻孔机

## Typical Applications/Cordless Power Tools

- Hand Tool
- Various Pumps
- Hair Clipper
- Paper Shredder
- Drill

型号 Model	电压 Voltage		无负载 No Load		最高效率时性能(%) At Maximum Efficiency				堵转 Stall	
	使用电压 Operating Range	常用 Nominal	转速(r/min) Speed	电流(A) Current	转速(r/min) Speed	电流(A) Current	扭矩(gcm) Torque	输出(W) Output	扭矩(gcm) Torque	电流(A) Current
GRS-5512PA-09220	AC Rect.	230 V	10700	0.025	9327	0.17	274.5	26.26	2140	1.154
GRS-5512PA-10150	AC Rect.	230 V	20000	0.050	17458	0.34	195.6	35.0	1538	2.360

GRS-5512PA-09220

230V AC

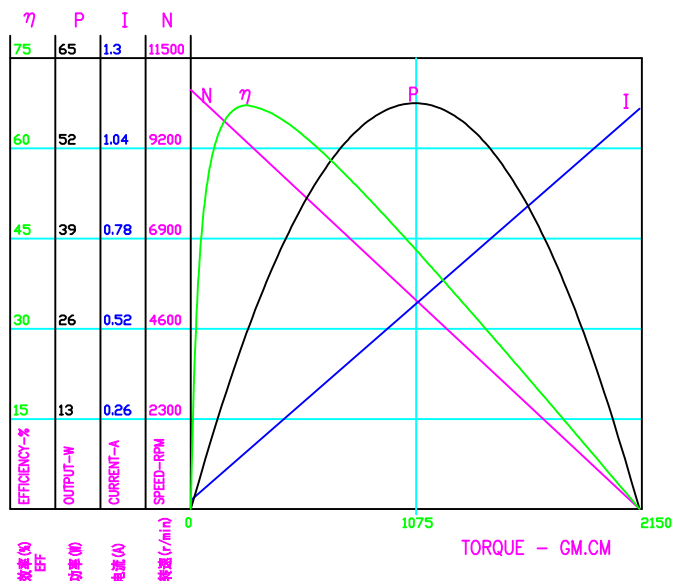

GRS-5512PA-10150

230V AC

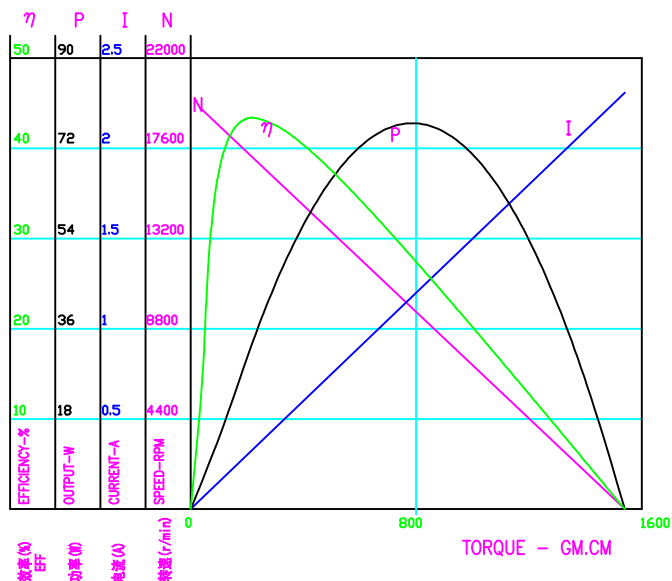

## DIRECTION OF ROTATION

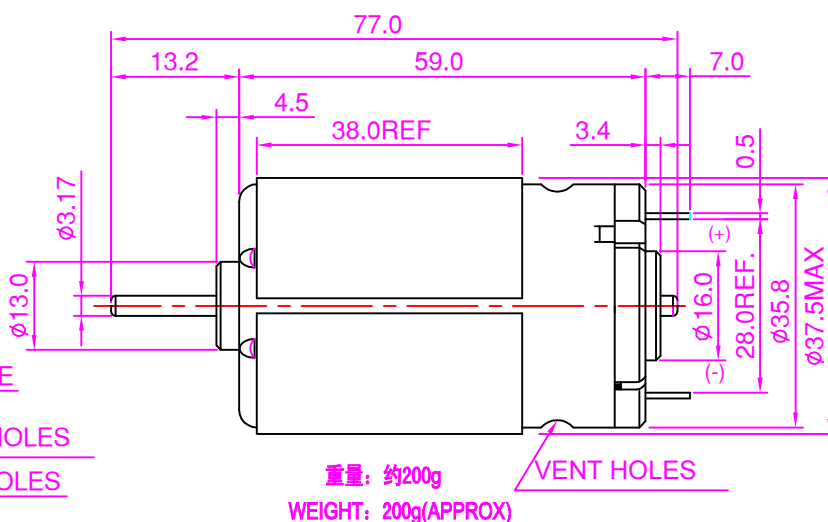
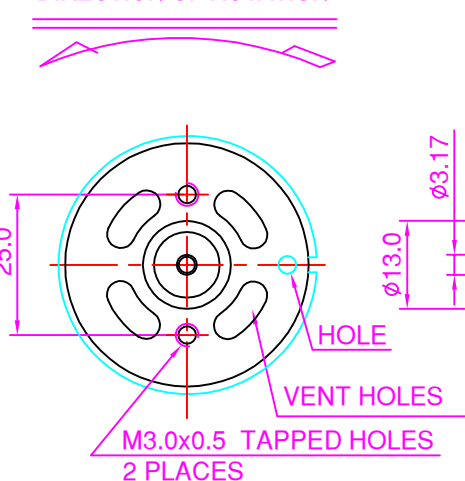

单位: mm

